

# INVESTIGATION BOX (WITH GLOVES & WINDOW)

Investigation box with build in led light and shielded gloves working size 500(W)\*400(D)\*406(H)



## Investigation box (with gloves & window) (500 x 400 x 406mm)

Investigation shielding box is designed for medium shielding performance of around 80 dB and keeping contact with the device under investigation.

The box is also equipped with shielded gloves so you can use and operate the appliances inside the box, without having to open the box and thus retains the shield.

By using the built-in LED lighting, it is possible to have a good view on the device and your hands inside the box.

## TECHNICAL SPECIFICATIONS

Shielding effect	≥65 Db
Interface type	See our filter modules
Number of filters	4
Working temperature(°C)	Normal work
Working Dimensions(mm)	500(W)*400(D)*406(H)
Outer Dimensions(mm)	547(W)*447(D)*438(H)
Weight (kg)	36
Appearance of color	Beige

\* Notice: dimensions are indicative

## SHIELDING PERFORMANCE\* (DB)

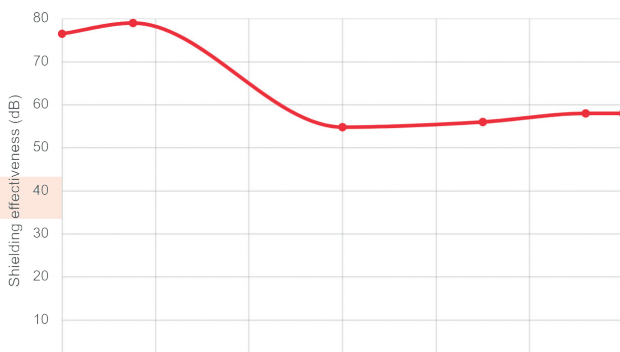

## FEATURES

- High levels of shielding attenuation, greater than 80 dB
- Box can be equipped with shielded power filters
- Connection in the box while still blocking all wireless signals
- Easy & Flexible operation in Lab and production line
- R&D, custom design

## GAS SPRINGS

The shielded box is equipped with gas springs that makes opening and closing the box easy.

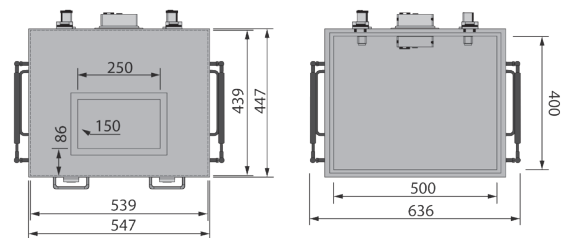
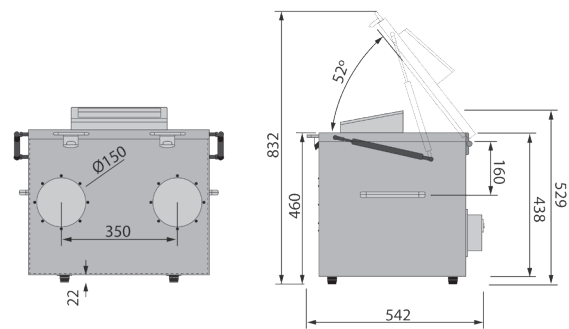

## ORDER EXAMPLE

Series

**MPSB504040**